

8 7 6 5 4 3 2 1

D

D

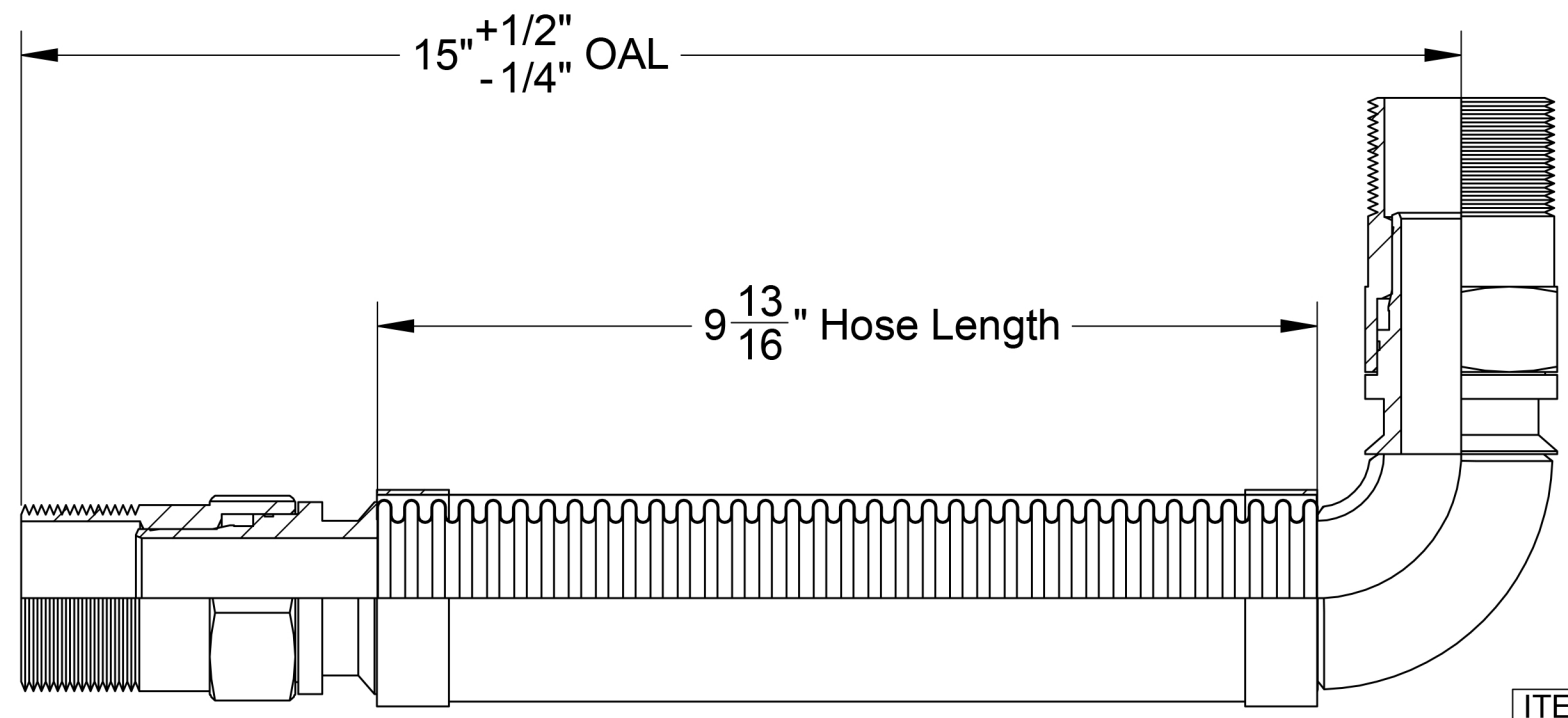

C

C

B

B

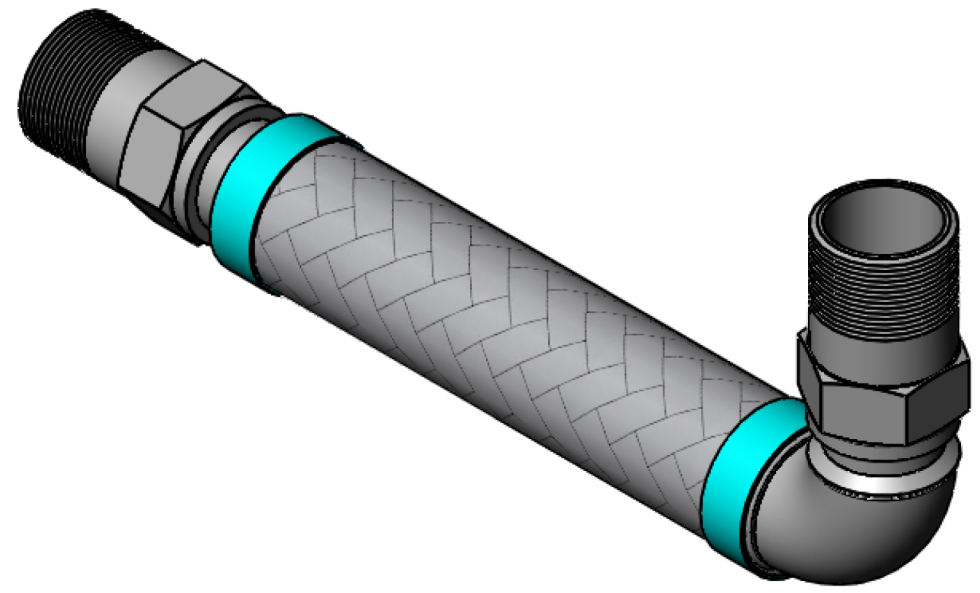

A

A

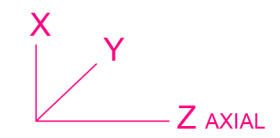

ITEM #	QTY.	PART NUMBER	DESCRIPTION	MATERIAL	WEIGHT
1	1	HOSE	300 Series Stainless HYDROFORMED Corrugated Hose	Stainless Steel	0.42
2	1	BRAID	300 Series Stainless Steel	Stainless Steel	0.04
3	2	BRAID COLLAR	0.05" Thick	Stainless Steel	0.07
4	2	1.5" MALE SWIVEL	1.5" Male Swivel, 1-1/2"x11-1/2" Thread, 1.94" Hex	Carbon Steel	1.40
5	1	1.5" ELBOW	1.5" Short Radius Elbow, Sch. 40	Carbon Steel	0.52



HOSE MASTER Inc.

1233 East 222nd Street • Cleveland, Ohio 44117
 (800) 221-2319 • Fax: (216) 481-7557 • www.hosemaster.com
 Locations: **Cleveland • Houston**

Registered to:
ISO 9001 : 2000



Projection:	Customer: Hose Master Inc.	Prepared By: kannk	
	Reference: Fire-Shield - 1.5" Male Swivel x 1.5" 90 Degree Male Swivel x 15 " OAL	CALC. WEIGHT: 4 lbs.	Date: 9/24/2009
	Description: 1.5" ID x 15" OAL 300 Series Stainless HYDROFORMED Corrugated Hose covered by 300 Series Stainless Braid. UL Approved 1.5" Male Swivel Connector x 1.5" ID 90 Degree Male Swivel Connector		
	Drawing #:	FSSSE0150x15	Rev.: - SHEET 1 OF 1

REVISIONS			
REV.	DESCRIPTION	DATE	APPROVED
8		7	6

8 7 6 5 4 3 2 1